

## **Analysis of Farmer Group Independence Reviewed from the Influence of Alsintan Assistance, Counseling Thought Group Dynamics (Study: Rice Field Farmer Group in Mungkajang District, Palopo City)**

**Andri<sup>\*</sup>, Sayafuruddin<sup>1</sup>, Andi Rizkiyah Hasbi<sup>1</sup>, Sapar<sup>1</sup>**

<sup>1</sup> Agricultural Extension Study Program, University of Muhammadiyah Palopo

\*Email Correspondence: [andrimuhammed@gmail.com](mailto:andrimuhammed@gmail.com)

### **ABSTRACT**

This study aims to analyze the influence of agricultural tools and machinery assistance (alsintan), counseling, and group dynamics on the independence of paddy rice farmer groups in Mungkajang District, Palopo City. The research method used is a quantitative approach with Structural Equation Modeling (SEM) analysis, which is supported by primary data through questionnaires, observations, and interviews with farmer group members. The independent variables in this study consisted of alsintan assistance and counseling, while group dynamics functioned as intervening variables that mediated the influence on group independence. The results of the analysis show that alsintan assistance does not always have a significant impact if it is not supported by good institutions and group management. On the other hand, counseling has been proven to play a significant role in increasing group independence, both directly and through strengthening group dynamics. Group dynamics serve as an important mediating variable that links external interventions to the achievement of independence, especially through leadership factors, cohesion, internal communication, and participatory decision-making. With a statistical T-value greater than the T-table and a P-Value smaller than  $\alpha$  (0.05), it can be concluded that counseling and group dynamics have a real and consistent effect on increasing the independence of farmer groups. This research provides practical implications that agricultural development policies should not only focus on providing physical assistance but also strengthen counseling and group institutional capacity as a long-term strategy towards sustainable smallholder independence.

Key words: food security, farmer empowerment, organizational effectiveness, role of government, sustainable smallholder

### **1. Introduction**

Farmer group independence is basically a concept that describes the ability of a group of farmers to manage a farming business independently, without relying excessively on external assistance. This independence is not only interpreted as freedom in accessing production factors, but also includes the group's ability to plan, implement, evaluate, and develop agricultural businesses in a sustainable manner [1]. According to [2], Farmers' independence can be realized through empowerment based on strengthening individual and institutional capacities, so that farmers have better technical skills, managerial abilities, and economic bargaining power. This definition emphasizes that independence is not born instantly but is the result of a long process through learning, strengthening the group's organizational structure, and supporting a conducive external environment.

The provision of Alsintan assistance also poses quite complicated governance challenges. Program evaluations and field reports found issues such as uneven distribution, unaccounted for maintenance costs, and the potential for the emergence of levy practices or irregularities during distribution. In addition, without strengthening operational capacity and institutional mechanisms for joint care, alsintan assistance risks becoming a source of dependence or damage and then not being used so that the expected productivity results are not maximized [3].

The government's hope is that with the help of alsintan, providing benefits for example (tractors, water pumps, handtractors) can reduce labor costs, reduce the time of pre-harvest activities, and allow the expansion of planting areas or intensification. This assistance will be successful if it is accompanied by operational training/technical knowledge and maintenance systems [3].

Agricultural extension is needed, which is a crucial spearhead that bridges technology transfer, adaptive cultivation practices, post-harvest management, and organizational learning for farmer groups. The effectiveness of extension can be measured from the frequency, participatory methods, relevance of materials, and capacity of extension workers positively correlated with technology adoption and increased farmers' income [4]. Counseling that is dialogical, field-based, and sustainable is able to improve the group's ability to care for alsintan and make collective decisions. Challenges to extension that are often reported include limited number of field extension workers, a top-down approach, and materials that are less adaptive to field conditions [5]. Counseling suggests a shift to a group-based learning model, master farmer training, and strengthening external agents who are facilitators, not just information presenters. In the research on the independence of farmer groups, the extension variable must be operationalized not only as the frequency of visits, but also the quality of interaction, learning methods, and sustainability of follow-up [6].

The measurable use of alsintan so that it can provide benefits to farmer groups requires the cooperation of all member elements through group dynamics. Dynamics are the socio-organizational elements that determine how assistance (alsintan) and counseling are internalized into collective practices or work together and are interrelated [7]. Relevant dynamics dimensions include leadership, organizational structure, norms and rules of common use, social cohesion, conflict resolution mechanisms, and external relations networks. Groups with participatory leadership, transparency in asset management, and an organized contribution/maintenance system tend to be more independent and more efficient in the utilization of aid. In contrast, groups with internal problems (conflict, elite dominance) often fail to manage shared assets on an ongoing basis [8].

Mungkajang District, according to statistical data and regional reports of Palopo City (Mungkajang District in 2024 Figures and BPS Palopo publications) shows that Mungkajang has a productive paddy field area and an active farming community, so it is a representative location for the study of the independence of paddy rice farmer groups. The 2023–2024 harvest documentation data also illustrates variations in irrigation conditions and responses to climate change that affect planting practices, so the independence analysis must consider the variables of alsintan assistance, extension variables and dynamics variables.

## **1.1. Literature Review and Hypothesis**

### ***1.1.1. Farmer Group Independence***

The definition of farmer group independence in a modern sense includes the sustainability dimension. This means that farmer groups are not only required to be independent in the short term, but also able to develop long-term strategies that are adaptive to environmental changes, both in terms of climate, technology, and market dynamics. [9] through a study on the Independent Farmer Program in Bojonegoro, it was found that the independence of farmer

groups can be increased through mastery of organic technology and diversification of farming businesses, so that the group is not only able to improve the welfare of members but also maintain environmental sustainability. Thus, independence is not only measured from technical or economic aspects, but also the ability to maintain the ecological sustainability of agriculture.

### **1.1.2. *Alsintan Assistance***

The definition of alsintan assistance also includes a strategic function in supporting national food security. Agricultural mechanization facilitated through the assistance of alsintan plays an important role in increasing the crop index (IP) and expanding the harvest area, so that it can increase food production [10]. Research [11] revealed that the help of tractors and water pumps increased the intensity of rice planting by up to 1.5 times in one year. Thus, alsintan assistance not only has implications for improving the welfare of farmers but also supports food self-sufficiency programs and rice price stability in the national market.

### **1.1.3. *Extension***

The definition of agricultural extension also needs to be understood in a global context. World Food and Agriculture Organization [12] defines counseling as a non-formal education service system that aims to improve the technical, managerial, and entrepreneurial skills of farmers. Modern counseling emphasizes the integration of digital information, global market systems, and adaptation to climate change. Thus, agricultural extension today is no longer limited to the local scope, but also globally oriented. Agricultural extension has undergone a major transformation through the use of information and communication technology (ICT). The concept of e-extension or digital extension allows farmers to access information through applications, social media, and online platforms. According to research [13], Counseling based on "Multimedia Content Creation for Agricultural Extension at the Limbangan Agricultural Extension Center (BPP)" has proven to be an effective solution to maintain extension worker interaction with farmers. This confirms that the current definition of counseling includes both traditional and modern technology-based approaches.

### **1.1.4. *Group Dynamics***

Agricultural group dynamics is a concept that describes the interactions, relationships, and social processes that occur among members of farmer groups in achieving common goals. According to [14], Group dynamics are internal forces that arise from the reciprocal relationships between group members, which then affect the effectiveness of achieving organizational goals. Group dynamics include aspects of cooperation, communication, leadership, participation, and social cohesion. This dynamic greatly determines the extent to which farmer groups are able to be independent in managing agricultural businesses, making collective decisions, and making optimal use of available resources.

Research related to alsintan assistance in Palopo City shows a relevant research gap: although the distribution of alsintan is quite intensive (especially in South Sulawesi in 2024), there have not been many studies that have simultaneously examined how the combination of alsintan assistance, the quality of counseling, and group dynamics affect the level of independence of farmer groups at the sub-district/city level such as Mungkajang District. Therefore, empirical studies that measure independence as a multidimensional outcome with technical, economic, and institutional indicators are needed to provide recommendations for more effective alsintan distribution policies, contextual counseling designs, and interventions

to strengthen group dynamics so that assistance truly leads to collective independence. To be clearer, a conceptual framework is made in Figure 1, as well as a research hypothesis.

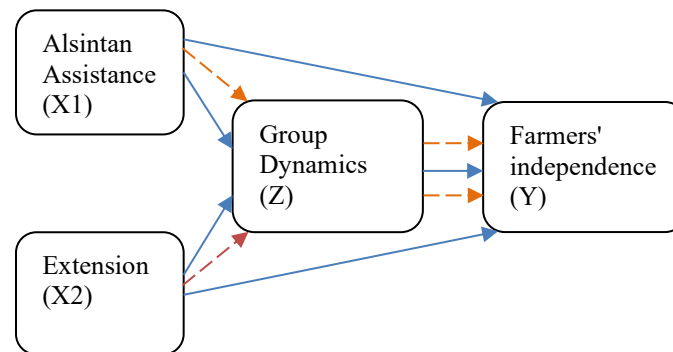

Figure 1. Conceptual Framework

Based on the conceptual framework in Figure 1, the following hypotheses are prepared:

1. It is suspected that the alsintan assistance has a positive and meaningful effect on the independence of the paddy field farmer group in Mungkajang District.
2. It is suspected that the counseling has a positive and meaningful effect on the independence of the paddy rice farmer group in Mungkajang District.
3. It is suspected that the assistance of alsintan has a positive and meaningful effect on the dynamics of the paddy field farmer group in Mungkajang District.
4. It is suspected that counseling has a positive and meaningful effect on the dynamics of the paddy rice farmer group in Mungkajang District.
5. It is suspected that group dynamics have a positive and meaningful effect on the independence of the paddy rice farmer group in Mungkajang District.
6. It is suspected that the assistance of alsintan has a positive and meaningful effect on the independence of the paddy rice farmer group in Mungkajang District through group dynamics as an intervening variable.
7. It is suspected that counseling has a positive and meaningful effect on the independence of the paddy field farmer group in Mungkajang District through group dynamics as an intervening variable.

## 2. Research Methods

This study uses a survey method with a quantitative descriptive analysis approach. The focus of this research is to analyze the Independence of Farmer Groups Reviewed from the Influence of Alsintan Assistance, Counseling and Group Dynamics (Study: Rice Field Farmer Group in Mungkajang District, Palopo City). This research will be carried out in September-October 2025 with a research permit from the Palopo City Government of the Investment and One-Stop Integrated Services Office Number: 500.16.7.2/2.25.1250/IP/DPMPSTP. The research location is in Mungkajang District, Palopo City. The area in this sub-district was chosen because some of the residents depend on the agricultural sector, especially rice plants, and receive alsintan assistance from the government. The location of Mungkajang District is also very inclusive because it is an urban area where some of the residents are still doing agriculture.

The population of this study is rice farmers with an age range of 25-60 years who are members of a farmer group totaling 84 people in Mungkajang District, Palopo City. The sampling technique uses the census technique. The size of the sample is determined by census technique, i.e. all populations become research samples [15]. The number of members and types of alsintan assistance received by farmer groups in Mungkajang District are presented in Table 1.

Table 1. Number of Members and Types of Assistance Equipment

NO	Name KLP Tani	Number of Members	Location	Alsintan Assistance
1	Kelompok Tani Rante	30	Mungkajang Village	Traktor, <i>Combine Harvester</i> , Water Pump
2	Kelompok Tani Bete-Bete	23	Murante Village	Tractor, Water Pump
3	Kelompok tani Jaya Makmur	31	Mungkajang Village	Tractor, Water Pump, <i>Combine Harvester</i>
Total		84 peoples		

The data analysis techniques in this study are descriptive statistical techniques and quantitative analysis of inferential statistics. Descriptive statistical analysis is a test to reveal the 'form' of data in perceiving how the values of a variable are distributed, whereas inferential statistical analysis is used to infer results derived from a sample in relation to population. A distinction is also made between the number of variables considered in relation to each other [16]. In this study, the analysis of deductive statistics used the EXCEL and SPSS programs. The imperative statistical analysis uses the *variance-based Structural Equation Modeling Partial Least Squares* (SEM-PLS) technique. The analysis tool used is smart PLS 4. PLS is a variant-based SEM statistical method designed to solve multiple regressions when specific problems occur in the data, such as small research sample sizes, missing *value* and *multicollinearity* [17].

### 3. Results and Discussion

#### 3.1. Respondent Demographics

This study involved 84 paddy farmers from four villages in Mungkajang District, Palopo City: Mungkajang Village, Murante Village, Latuppa Village, and Kambo Village. This descriptive data of respondents provides brief information about the condition of the respondents who are the subject of the study. Respondents were described based on gender, age, education, and length of farming.

Table 2. Respondent Characteristics

No	Demography	Frequency	Percentage (%)
1	Gender		
	Man	68	84
	Woman	13	16
2	Age		

	21 sd 40 yrs	6	7,4
	41 sd 60 yrs	54	66,7
	> 61yrs	21	25,9
3	Education		
	No School	2	2,5
	Primary school	4	4,9
	Junior High School/Equivalent	17	21,0
	High School/Equivalent	52	64,2
4	Bachelor	6	7,4
	Long Farming		
	< 5 yrs	13	16,0
	6 sd 10 yrs	30	37,0
	>11 yrs	38	46,9

In Table 2, it is known that the number of female respondents is 13 people (16%) and 68 people (84%) for men. The average age between 21-40 years is 6 people (7.4%), 41-60 years old as many as 54 people (66.7%), and > age 61 years old as many as 21 people (25.9%). The overall education level of respondents was mostly 52 high school graduates (64.2%), 2 people (2.5 people out of school), 4 elementary school (4.9%), junior high school education (215) and 6 undergraduate education (7.4%).

### 3.2. Inferential Analysis

#### 3.2.1. Model validity test

The purpose of an external model or external measurement, also referred to as a reflective measurement model, is to find the relationship between latent variables and their indicators. The PLS Algorithm procedure was used to perform the external test of this model [18]. In Gamgar 2, it was found that the outer loading value of each variable indicator had met the validity value with a value of >0.7. Therefore, the research model is declared valid.

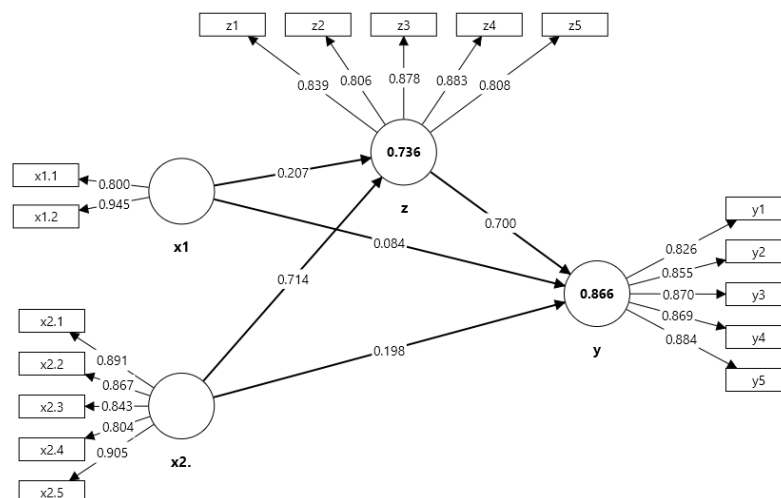

Figure 2. SEM Model Analysis (Output smart-PLS)

To find out the level of validity of the reflective model indicator. *Average Variance Extracted* (AVE), with an expected value of more than 0.5, in Table 3, the AVE value of each variable in the study is greater than 0.5, so that the analyzed SEM model can be declared valid.

Table 3. Value AVE

Variables	AVE
(X1) Alsintan Assistance	0,766
(X2) Group Dynamics	0,744
(Y) Independence of KLP Tani	0,741
(Z) Extension	0,711

The composite reliability values and Cronbach Alpha are used to determine the reliability level of the SEM model. This reliability value is used to measure the internal reliability level of a variable indicator. Cronbach's Alpha standard value for a variable is considered reliable if its value is more than 0.6, while the standard Composite Reliability value is more than 0.7. Based on Table 4, it is known that all variables have a *Cronbach's Alpha* value of more than 0.6 and a *Composite Reliability* (CR) value of more than 0.7, so it can be stated that the analyzed SEM model is reliable.

Table 4. CR and *Cronbach's Alpha* Values

Variable	Cronbach's Alpha	CR
(X1) Alsintan Assistance	0,717	0,905
(X2) Group Dynamics	0,914	0,922
(Y) Independence of KLP Tani	0,913	0,913
(Z) Extension	0,898	0,901

Determinant analysis (*R Square*) is to see the magnitude of the influence of independent variables together affecting dependent variables with criteria according to [19] states that the *value of R square* 0.75 is included in the strong category, the *value of R square* 0.50 is included in the moderate category and *the value of R square* 0.25 is included in the weak category.

Table 5. R Square Analysis Results

Variable	R Square
(Y) Independence of KLP Tani	0,866
(Z) Group Dynamics	0,736

Based on Table 5, it can be seen that the variable (X1) and the variable X2, together with (Z) with a result of 0.866 or 86.6%, can be said to be strong criteria. While the variable (X1), and X2 affect (Z) simultaneously by 0.736 or 73.6% can be said to be a moderate criterion.

F Square analysis is to assess how much influence there is between variables using Effect Size or F-square. The value of F-square is interpreted as follows: 0.02 is considered small, 0.15 is considered medium, and 0.35 is considered large. If the value is less than 0.02, then the effect can be ignored or considered non-existent [20]. Based on Table 6 of the F-Square

value above, the large size effect with the F-Square criterion  $> 0.35$  is the effect of Group Dynamics (X2) on Counseling (Z) with a value of F-square 1,184, and the effect of Extension (Z) on the Independence of KLP Farmers (Y) with an F-square value of 0.966, while the medium size effect is with F-square between 0.15 to 0.35 is the effect of Alsintan Assistance (X1) on Group Dynamics (X2) with a value of 0.029, the effect of Alsintan Assistance (X1) on Counseling (Z) is 0.099, the effect of Group Dynamics (X2) on Group Dynamics (X2) with a value of 0.082. The value of F-square indicates that there is no influence between variables whose value is  $< 0.02$ .

Table 6. F Square

	<i>F-square</i>
x1 -> y	0,029
x1 -> z	0,099
x2 -> y	0,082
x2 -> z	1,184
z -> y	0,966

analysis results

### 3.3. Inner Model Test Results

#### 3.3.1. Statistical T Analysis

Statistical T analysis aims to determine the magnitude of the influence between variables. Statistical T Values  $> T$  Table shows the influence of positive and significant variables with P Values  $< 0.05$ . The internal analysis of the SEM model was used to see the magnitude of the Statistical T value and the P Value which is also a measure of the strength of the influence of independent variables on dependent variables.

Table 7. Statistical T Analysis Value

Variable	T statistics ( O/STDEV )	P values	Criterion
x1 -> y	1,401	0,161	rejected
x1 -> z	2,310	0,021	Accepted
x2 -> y	2,401	0,016	Accepted
x2 -> z	9,547	0,000	Accepted
z -> y	7,816	0,000	Accepted
x1 -> z -> y	2,100	0,036	Accepted
x2 -> z -> y	6,485	0,000	Accepted

Based on the results of the analysis of T Statistics as shown in Table 7, the hypothesis test of independent variables against dependent variables can be stated as follows:

**Hypothesis 1:** It is suspected that (X1) has a positive and significant effect on (Y). The results of SEM analysis obtained statistical  $T = 1,401 < t \text{ table} = 1.664$  with a P Value =  $0.161 > \text{Cut off Value}$  of 0.05, hypothesis 1 was rejected.

**Hypothesis 2:** It is suspected that (X1) has a positive and significant effect on (Z). The results of SEM analysis were obtained T statistic =  $2,310 > t \text{ table} = 1.664$  with P Value =  $0.021 < \text{Cut off Value}$  of 0.05, hypothesis 2 accepted.

**Hypothesis 3:** It is suspected that (X2) has a positive and significant effect on (Y). The results of SEM analysis were obtained T statistics = 2,401 > t table = 1.664 with P Value = 0.016 < *Cut off Value* of 0.05, hypothesis 3 was accepted.

**Hypothesis 4:** It is suspected that (X2) has a positive and significant effect on (Z). The results of SEM analysis were obtained T statistics = 9,547 > t table = 1,664 with P Value = 0.000 < *Cut off Value of 0.05*, hypothesis 4 was accepted.

**Hypothesis 5:** It is suspected that (Z) has a positive and significant effect on (Y). The results of SEM analysis obtained T statistics = 7,816 > t table = 1,664 with P Value = 0.000 < *Cut off Value of 0.05*, hypothesis 5 accepted.

**Hypothesis 6:** It is suspected that (X1) has a positive and significant effect on (Y) through (Z) as an intervening variable. The results of SEM analysis obtained T statistics = 2,100 > t table = 1.664 with P Value = 0.036 < *Cut off Value of 0.05*, hypothesis 6 accepted.

**Hypothesis 7:** It is suspected that (X2) has a positive and significant effect on (Y) through (Z) as an intervening variable. The results of SEM analysis obtained T statistics = 6,485 > t table = 1,664 with P Value = 0.000 < *Cut off Value of 0.05*, hypothesis 7 accepted.

### 3.4. Discussion

#### **Alsintan assistance affects the independence of the paddy rice farmers group in Mungkajang District**

Based on the results of the analysis of respondents' responses, the variable of Alsintan assistance was not proven to have a positive and significant influence on the independence of Farmer Groups in Mungkajang District, with the results of the SEM analysis obtained a statistical T value = 1,401 and a P value = 0.161 ( $> \alpha = 0.05$ ), so the hypothesis was rejected. The statistical T-value that is less than the table T-value shows that the contribution of Alsintan assistance to the independence of the Farmer KLP has no real effect and is inconsistent. Meanwhile, the P Value, which has a value greater than the value of  $\alpha$ , confirms that the relationship is almost non-existent or unrelated, so statistically the research hypothesis is rejected.

These results show that the mechanism for using Alsintan given by the government to farmer groups is not optimal, where the assistance is not distributed evenly, and its use is only used by a handful of group administrators. The service as a regulator, dynamizer, and facilitator, is less active and does not optimally supervise the use of Alsintan assistance in Mungkajang District. This role can include the formulation of agricultural policies that are in favor of all farmers, facilitating access to Alsintan assistance that can be distributed evenly by all members of farmer groups.

Studies have shown different results on the impact of Alsintan assistance on the independence of farmer groups; some have found positive effects on productivity and income but not automatically on institutional independence. The study, "national evaluative studies and multisite case studies" shows that Alsintan improves the efficiency and productivity of farming (reduced tillage costs, acceleration of the work cycle), but these benefits are often individual or technical, so they do not directly affect the improvement of group independence without clear management support, training, and service models. The results of this study are consistent with

studies that examine that the existence of machines is not enough; governance, maintenance models, and service *provision* are needed so that Alsintan becomes a driver of collective independence, not just technical productivity. Multisite studies assessing the effectiveness of distribution reported on the gap between tool allocation and institutional/HR readiness at the farmer group level, resulting in weak or inconsistent effects on group independence [21].

Research focusing on the extension model and utilization scheme shows that Alsintan interventions accompanied by structured assistance models and service mechanisms (e.g., organized rental services, the establishment of machine service units, or partnerships with private actors) tend to produce significant effects on socio-economic changes and group organizational capacity. Conversely, if the distribution of equipment is carried out without strengthening the group's managerial capacity, maintenance standards, and operational financing mechanisms, the impact is limited, this supports your statistical interpretation that the relationship between Alsintan assistance and group independence in Mungkajang "hardly occurs." Several case studies in Palopo and other regions found that when intermediate variables such as extension effectiveness, technology adoption, and tool business model were incorporated into the SEM analysis model, Alsintan's direct influence on self-reliance became more apparent through *mediated effects*, rather than direct influences [22].

Compared to the research that recommends improving Alsintan's governance and service model, the results of the study confirm that the tool distribution policy must be complemented by institutional strengthening strategies, including collective asset management schemes, technical and managerial training, and utilization monitoring, so that Alsintan's contribution to the independence of farmer groups becomes real. Other studies have also shown the need for longitudinal evaluation: some independence effects emerge so slowly (it takes several growing seasons) that cross-sectional studies may fail to capture the dynamics of capacity building. Therefore, in addition to recommending technical and managerial interventions, cross-time comparative research and the use of mixed-method approaches will help elucidate the complex causal pathway between Alsintan distribution and farmer group self-sufficiency [21], [22].

### **Counseling affects the independence of the paddy field farmer group in Mungkajang District**

Based on the results of the analysis of respondents' responses, the extension variable was proven to have a positive and significant influence on the independence of Farmer Groups in Mungkajang District, with the results of the SEM analysis obtained a statistical T value = 2,401 and a P value = 0.016 ( $< \alpha = 0.05$ ), then the hypothesis was accepted.

The statistical T-value is greater than the table T-value shows that the contribution of the influence of extension to the independence of the Farmer KLP has a real and consistent effect. Because the results of the analysis show that the P Value is smaller than the value  $\alpha$  confirms that the relationship is interrelated, so statistically the research hypothesis is accepted.

The results of the study's SEM analysis showing a statistical T-value ( $T = 2.310$ ;  $p = 0.021$ ) showing a positive and significant effect of extension on the independence of farmer groups are in line with a number of empirical studies that confirm that structured extension

interventions, including technical training, field demonstrations, and participation-based counseling, often improve farmers' technical capabilities, technology adoption rates, and collective organizing capacity that are a key component of institutional independence. The results of this analysis not only show statistical but also coherent relationships with causal patterns identified in previous research studies: counseling serves as a driver of new knowledge and practices that, when implemented consistently, strengthen the group's internal capacity to manage resources, maintain shared assets, and design counseling service mechanisms [23].

Causal mechanisms and evidence from research on why counseling shows a significant effect on self-reliance, research that analyzes the improvement of managerial skills, the formation of social networks/knowledge, and increased access to technical innovation, which mediates between extension activities and institutional outcomes. Case studies using the SEM model found that the effects of counseling on indicators of self-reliance often occur through indirect channels: counseling increases practice adoption and innovation, which in turn improves income, social capital, and ultimately the group's ability to operate independently. This study, which uses SEM and obtains direct significance, is consistent with the literature, especially if counseling in Mungkajang District contains participatory elements, high frequency, and institutional strengthening components, therefore theoretically the direct influence (counseling → independence) can have a significant effect in this study. Other studies that assessed digital (*mobile-based*) counseling and the lead-farmer approach also found a similar pattern: the quality, continuity, and relevance of the counseling material determined the strength of the effect [24].

The effect of effective counseling on positive contributions means that the program must emphasize quality (trained trainers, contextual materials, follow-up) and institutionalization (routine schedules, monitoring instruments, integration into BPP/Agriculture Office) so that the significant effect is sustainable. Although the results show a positive influence, it is still a reminder to interpret carefully: the long-term effects on institutional independence are sometimes only seen after several growing seasons, so the corresponding research will reinforce the results. Research should also combine counseling with supporting incentives (access to capital, after-sales services, markets) so that capability enhancement can be transformed into institutional economic independence [23], [25].

### **Alsintan assistance affects the dynamics of the paddy rice farmer group in Mungkajang District**

Based on the results of the analysis of respondents' responses, the variable of Alsintan assistance was proven to have a positive and significant influence on the dynamics of Farmer Groups in Mungkajang District, with the results of the SEM analysis obtained a statistical T value = 2,310 and a P Value = 0.021 ( $< \alpha = 0.05$ ), then the hypothesis was accepted. The statistical T-value is greater than the table T-value shows that the contribution of Alsintan assistance to the dynamics of Farmer KLP has a real and consistent effect. Because the results of the analysis show that the P Value is smaller than the value  $\alpha$  confirms that the relationship is interrelated, so statistically the research hypothesis is accepted.

The results of the analysis of Alsintan assistance have a significant effect on the dynamics of farmer groups in line with the results of the research "A case with a group of farmer groups in Indonesia" by [26]. The study examines how farmer groups in several regions are able to strengthen organizational structures, leadership, and internal governance through the collective management of technological assistance and agricultural tools. The use of Alsintan or mechanized equipment, when accompanied by clear arrangements for use, maintenance, and benefit-sharing, can strengthen group dynamics, such as aspects of member cooperation, participation in decision-making, and collective capacity to face external challenges. The results of statistical analysis found that the T-statistics were greater than the T of the table and the p value was far below 0.05, this study also reported a significant coefficient for the mechanization assistance variable against the institutional dynamics indicator.

The positive influence of Alsintan's assistance on group dynamics did not appear by chance, but through several important mediation mechanisms and control variables. For example, in the article "*Barriers, drivers, and pathways for sustainable agri-food*" by [27], It was explained that although the mechanization and assistance of agricultural tools are the driving factors, their effectiveness is influenced by the existence of support systems such as equipment management training, after-sales service, access to spare parts, and regulations on their use. These indicators (training, maintenance, institutional support) reinforce the effect of Alsintan's assistance on the internal dynamics of the group, such as member coordination, joint planning, and group leadership. The results of this study found that Alsintan assistance had a statistically significant influence on dynamics; Differences in the quality of aid implementation (e.g. whether their use is collective and well managed) are likely to be factors that make the effect consistent and significant.

Important implications arise for further policy and research, namely: First, the distribution of Alsintan assistance must be accompanied by institutional strengthening instruments so that its impact on the dynamics of farmer groups is maximized: technical training, group organization, tool maintenance mechanisms, cost-and-benefit sharing regulations, and participatory monitoring. Second, policies must ensure that assistance is not only physical (tools), but also institutional and social, so that farmer groups are collectively able to make decisions, manage assets, resolve conflicts of use, keep tools functional and provide long-term benefits. Third, for further research: although the results find immediate significance, it is important to use a longitudinal analysis model so that the effects of dynamics are seen over time, not just cross-sectionally. In addition, further research should include mediation/moderation variables such as group leadership, social capital, intensity of tool utilization, and quality of support services (training, spare parts, technical counseling). Fourth, cross-regional comparisons would be helpful: for example, geographical conditions, market access, the organizational culture of farmer groups, and different levels of technical dependency can strengthen or weaken the influence of Alsintan assistance on the group's institutional dynamics.

### **Counseling affects the dynamics of the Rice Farmers Group in Mungkajang District**

Based on the results of the analysis of respondents' responses, the extension variable was proven to have a positive and significant influence on the dynamics of Farmer Groups in Mungkajang District, with the results of the SEM analysis obtained a statistical T value = 9,547 and a P value = 0.000 ( $\alpha = 0.05$ ), then the hypothesis was accepted. The statistical T-value is greater than the table T-value shows that the contribution of the influence of extension to the dynamics of the Farmer KLP has a real and consistent effect. Because the results of the analysis show that the P Value is smaller than the value  $\alpha$  confirms that the relationship is interrelated, so statistically the research hypothesis is accepted.

The results of the study showing a very strong influence of extension (T = 9,547; p Value = 0.000) are in line with a number of previous empirical studies that showed that high-quality extension services have a real impact on the collective behavior and institutional dynamics of farmer groups. Participatory, sustainable, and contextual counseling increases the adoption of agricultural practices, members' technical capacity, and the interaction and coordination between members that are at the core of the group's "dynamics" (increased participation, division of tasks, and collective decision-making). With a very small p-value in the SEM model analysis, the results of this study show an effect that is not only statistically significant but also substantive on a pattern that is in line with previous research that assessed the effectiveness of modern extension on institutional outcomes of farmers [28].

The strong influence of counseling provides a mechanistic explanation that helps to interpret why the influence of counseling on group dynamics can be so great. Based on previous research, counseling improves technical knowledge and managerial practices (record keeping, planting planning, management of shared tools), which in turn strengthens social capital (trust between members and networks) thereby encouraging collective coordination and joint initiative, a core component of group dynamics. In addition, the recent study also emphasized the quality of counseling (frequency, local relevance, participatory methods, and the existence of follow-ups) as the main determinants of effect measures; Intensive and continuous counseling is able to produce more permanent behavioral changes and increase the capacity of group organizations [23], [29].

The results of this study have significant consequences for policy and subsequent research. First, the results of this study suggest that the quality of counseling requires an increase in not only the number of meetings, but also instructor training, contextual materials, and follow-up mechanisms, as these components have a greater impact on group dynamics. Second, the incorporation of counseling with supporting packages (such as organizational facilities, market access, and after-service Third, although the research findings are statistically significant, you should be careful in causal inferences because organizational effects and dynamics can change over time, so panel or longitudinal studies will be more powerful in providing causal evidence than cross-sectional snapshots [29].

### **Group dynamics affect the independence of the paddy field farmer group in Mungkajang District**

Based on the results of the analysis of respondents' responses, the group dynamics variable was proven to have a positive and significant influence on the independence of Farmer

Groups in Mungkajang District, with the results of the SEM analysis obtained a statistical T value = 7,816 and a P value = 0.000 ( $< \alpha = 0.05$ ), then the hypothesis was accepted. The statistical T-value is greater than the table T-value shows that the contribution of the influence of group dynamics on the independence of the Farmer Group has a real and consistent effect. Because the results of the analysis show that the P Value is smaller than the value  $\alpha$  confirms that the relationship is interrelated, so statistically the research hypothesis is accepted.

Based on the results of the statistical analysis using SEM, it was found that the group dynamics variable was proven to have a positive and significant influence on the independence of Farmer Groups in Mungkajang District, with a statistical T value = 7.816 and  $p = 0.000$  ( $< \alpha = 0.05$ ). These findings show that farmer groups with a high level of internal dynamics, including aspects such as communication between members, clear division of tasks, responsive leadership, and collective coordination and decision-making, are better able to manage resources, shared assets, and formulate internal strategies to increase institutional independence. These results are in line with the research "*Supporting self-organisation in farmer organisations in developing countries: A case with a group of farmer groups in Indonesia*" by [26] which shows that farmer groups that are successful in *self-organizing*, involving members in *co-creation governance*, and having an adaptive internal institutional structure, show greater capacity to face challenges and strengthen their position without continuing to rely on external support.

Other research also supports the pathway of mechanisms through which group dynamics affect independence. Research [30] Self-organization processes that include member consultation, internal rulemaking, and adaptation to external changes have been proven to strengthen member commitment and group organizational capacity in making joint decisions and managing collective assets. Internal social capital (trust between members, solidarity), effective communication, and a clear leadership structure are important mediators between group dynamics and organizational outcomes such as institutional independence. This mediation mechanism is consistent with the SEM model: group dynamics are not only a direct variable, but also as an internal capacity drive that makes farmer groups more independent in asset management, decision-making, and maintenance of shared tools/services.

Based on the findings of previous research and theoretical studies, it is suggested that governments and agricultural development institutions should first make interventions that prioritize programs that improve the organizational dynamics of farmer groups, such as member leadership training, facilitation of internal communication, drafting of internal regulations, clarity of the role of members, and routine coordination systems. To strengthen causal inference, it is recommended that in future studies use panel or longitudinal design so that group dynamics and independence can be monitored at all times. Third, insert moderation variables or other mediators into the SEM model. This includes factors such as social capital coming from external sources, such as NGO networks or governments; level of counseling intervention or tool assistance; access to markets and raw materials; and the intensity of group members' participation.

### **Alsintan assistance to the independence of the paddy rice farmers group in Mungkajang District through group dynamics as an intervening variable**

Based on the results of the analysis of respondents' responses, the variable of Alsintan assistance was proven to have a positive and significant influence on the independence of Farmer Groups through group dynamics as an intervening variable in Mungkajang District, with the results of the SEM analysis obtained a statistical T value = 2,100 and a P Value = 0.036 ( $\alpha = 0.05$ ), then the hypothesis was accepted. The statistical T-value is greater than the T value of the table shows that the contribution of the influence of alsintan assistance on the independence of the Farmer Group through the mediation/intervening variables of group dynamics has a real and consistent effect. Because the results of the analysis show that the P Value is smaller than the value  $\alpha$  confirms that the relationship is interrelated, so statistically the research hypothesis is accepted.

Based on the results of the SEM analysis which shows that the Alsintan assistance variable has a positive and significant effect on the independence of the Farmer Group through group dynamics as an intervening variable ( $T = 2,100$ ;  $p\text{-value} = 0.036$ ), it can be affirmed that the existence of Alsintan not only provides technical benefits in the production process, but also encourages the strengthening of social interaction and group organization. This is in line with research [31] which emphasizes that the effects of agricultural technology interventions are rarely direct but are mediated by institutional factors and social dynamics formed within farmer groups. Thus, Alsintan functions as a catalyst that changes the pattern of interaction, coordination, and division of roles within the group, thereby increasing the chances of realizing institutional independence. These results support the argument that agricultural technology innovation requires the support of the group's internal social capital in order to be effectively utilized in the long term.

In addition, the mediation mechanism through group dynamics can be further explained through several important indicators, namely social capital, managerial capacity, and after-sales service support. [32] It shows that internal social networks, trust between members, and participatory leadership are key factors that enable farmer groups to optimize agricultural tools collectively. When the group is able to build a system of common rules, set a schedule of use, and manage maintenance costs in a cooperative manner, Alsintan transforms from a mere physical input to an institutional asset. [33] also affirms that strong managerial capacity. Includes recording, evaluation, and coordination between members, strengthening the group's ability to manage external assistance so that it can be transformed into an independent resource.

The results of the research are consistent with the study of agricultural innovation by [34], emphasized that the distribution of Alsintan is not enough to be oriented only to physical provision, but must be accompanied by a program to strengthen the group's institutions. Local governments and extension agencies need to design integrated policy packages, including leadership training, facilitation of internal regulatory drafting, and the development of transparent coordination mechanisms. Furthermore, a longitudinal research design is suggested to capture the long-term effects of group dynamics on independence, given that the effects of mediation are cumulative. Follow-up research also needs to examine moderator factors, such as group size, member education level, and market access, to determine the contextual conditions that strengthen the effectiveness of Alsintan assistance.

## **Counseling on the independence of paddy rice farmer groups in Mungkajang District through group dynamics as an intervening variable**

Based on the results of the analysis of respondents' responses, the extension assistance variable was proven to have a positive and significant influence on the independence of the Farmer Group through group dynamics as an intervening variable in Mungkajang District, with the results of the SEM analysis obtained a statistical T value = 6,485 and a P Value = 0.036 ( $\alpha = 0.05$ ), then the hypothesis was accepted. The statistical T-value is greater than the T value of the table shows that the contribution of the influence of extension to the independence of Farmer Groups through mediation/intervening variables of group dynamics has a real and consistent effect. Because the results of the analysis show that the P Value is smaller than the value  $\alpha$  confirms that the relationship is interrelated, so statistically the research hypothesis is accepted.

The results of the SEM analysis showed that the extension assistance variable had a positive and significant effect on the independence of the Farmer Group through group dynamics as an intervening variable ( $T = 6,485$ ;  $p = 0.036 < \alpha = 0.05$ ). These findings indicate that counseling not only has a direct impact on individual capacity building but also triggers a transformation of the group's internal dynamics which in turn promotes institutional independence. Research [30] emphasized that farmer empowerment policies in Indonesia, including through counseling, play an important role in increasing the collective capacity of groups and strengthening farmers' bargaining positions in the market. Counseling that is designed in a participatory manner has been proven to be able to improve internal communication, clarify the division of roles, and increase member motivation so that the decision-making process becomes more independent. Thus, the results of this study show that counseling has a dual function, namely as a means of technical knowledge transfer as well as a social instrument to strengthen group dynamics.

Furthermore, the mechanism of the influence of counseling through group dynamics can be explained through social capital indicators and institutional capacity strengthening. [26] found that co-creation *governance-based counseling* strengthens the self-organization of farmer groups in Indonesia. This increase in organizational capacity allows groups to form internal rules, enforce collective discipline, and optimize the use of shared resources. Similar results were also shown by [32], which emphasizes that knowledge-based interventions encourage the formation of stronger social and institutional networks, which ultimately contribute to the sustainability of agricultural systems. Thus, group dynamics serve as a mediating bridge that allows counseling at the individual level to transform into collective independence at the institutional level.

These findings have important implications for agricultural development policy. First, the results of the research that are consistent with the latest literature affirm the importance of integrating extension programs with strategies to strengthen the institution of farmer groups. Counseling should not only be directed at improving production technical skills but should also be focused on facilitating group dynamics processes such as leadership, internal communication, and participatory governance. Second, longitudinal research is recommended to capture the development of the mediated effect of counseling on group independence in a

sustainable manner. Third, future research may test moderating factors, such as education level, land area, or market access, that may affect the strength of relationships between variables. Thus, counseling can be understood as a multifunctional intervention that significantly strengthens the independence of farmer groups through their internal dynamics.

#### 4. Conclusion

Based on the results of the study, it can be concluded that: alsintan assistance has not consistently had a significant influence on the independence of farmer groups if it is not supported by fair management, maintenance, and distribution systems. Counseling has been proven to have a positive and significant influence, both directly and through group dynamics, on increasing the independence of farmer groups. Group dynamics play an important role as an intervening variable that strengthens the relationship between external interventions (alsintan assistance and counseling) and group independence, through aspects of leadership, cohesion, common norms, and internal communication.

For the Government: Alsintan assistance needs to be integrated with continuous counseling programs and technical assistance so that its utilization is optimal and supports group independence. For Agricultural Extension Workers: The focus of extension is not only on the technical aspects of cultivation, but also on strengthening group dynamics, participatory leadership, and collective decision-making. For Farmer Groups: It is expected to be more active in maintaining cohesion, building effective communication, and implementing internal rules consistently so that assistance and supporting programs can have a maximum impact on independence. For Further Researchers: It is recommended to conduct longitudinal studies to see the dynamics of the influence of aid, counseling, and group institutions.

#### 5. References

- [1] S. Abdullah, Suriana, Y. Jayadisastra, Bunyamin, and Anjasmara, "Tingkat Keberhasilan Kinerja Penyuluh dalam Meningkatkan Sumberdaya Petani Padi Sawah di Desa Tanah Poleang, Kecamatan Poleang Utara," *Jurnal Penyuluhan*, vol. 19, no. 01, pp. 181–195, Apr. 2023, doi: 10.25015/19202343679
- [2] C. Jufrianda, Solfema, and L. D. Putri, "Wujudkan Kemandirian Petani Melalui Pemberdayaan Kelompok Tani," *Journal Innovation in Education*, vol. 3, no. 1, pp. 27–32, Dec. 2025, doi: 10.59841/INOVED.V3I1.2065.
- [3] Syafruddin and M. Risal, "Pengaruh Penyuluhan terhadap Dampak Sosial Ekonomi Petani Penerima Bantuan Sarana Prasarana Pertanian di Kota Palopo," *Jurnal Penyuluhan*, vol. 20, no. 02, pp. 203–213, Sep. 2024, doi: 10.25015/20202447989.
- [4] J. Ramjattan, A. Chowdhury, and W. Ganpat, "Agricultural extension agents' use of learning-based extension methods in Trinidad and Tobago," *Journal of Learning for Development*, vol. 7, no. 2, pp. 142–160, 2020, doi: 10.56059/jl4d.v7i2.378.
- [5] C. Ragasa, J. Ulimwengu, J. Randriamamonjy, and T. Badibanga, "Factors Affecting Performance of Agricultural Extension: Evidence from Democratic Republic of Congo," *Journal of Agricultural Education and Extension*, vol. 22, no. 2, pp. 113–143, 2016, doi: 10.1080/1389224X.2015.1026363.
- [6] J. C. Aker, "Dial 'A' for agriculture: A review of information and communication technologies for agricultural extension in developing countries," *Agricultural Economics*, vol. 42, no. 6, pp. 631–647, 2011, doi: 10.1111/j.1574-0862.2011.00545. x.

- [7] N. A. Purwatiningsih, A. Fatchiya, and R. S. H. Mulyandari, "Pemanfaatan Internet dalam Meningkatkan Kinerja Penyuluh Pertanian di Kabupaten Cianjur," *Jurnal Penyuluhan*, vol. 14, no. 1, 2018, doi: 10.25015/penyuluhan.v14i1.17173.
- [8] J. B. Stevens, "Sustainable agriculture development through effective farmer groups," *South African Journal of Agricultural Extension*, vol. 33, no. 1, pp. 40–51, 2004.
- [9] D. Armant and B. Kurniawan, "Efektivitas Program Petani Mandiri (PPM) dalam Meningkatkan Kesejahteraan Keluarga Petani di Desa Beji Kecamatan Kedewan Kabupaten Bojonegoro," *Publika*, vol. 11, no. 1, pp. 1539–1552, 2022, doi: 10.26740/publika.v11n1.p1539-1552.
- [10] A. rizkiyah Hasbi, W. P. Astuti, and M. Surullah, "Pengaruh Bantuan Alat Mesin Pertanian dalam Meningkatkan Pendapatan Petani Sawah di Kelurahan Sendana, Kecamatan Sendana Kota Palopo," *PLANTKLOPEDIA: Jurnal Sains dan Teknologi Pertanian*, vol. 4, no. 1, pp. 17–27, Mar. 2024, doi: 10.55678/PLANTKLOPEDIA.V4I1.1334.
- [11] H. Tarigan, "Mekanisasi Pertanian dan Pengembangan Usaha Pelayanan Jasa Alsintan (UPJA)," *Forum penelitian Agro Ekonomi*, vol. 36, no. 2, 2019, doi: 10.21082/fae.v36n2.2018.117-128.
- [12] FAO, "The State of the World's Biodiversity for Food and Agriculture," Rome, 2019. Accessed: May 19, 2025. [Online]. Available: <http://www.fao.org/3/CA3129EN/CA3129EN.pdf>
- [13] E. Hernawati, I. Gartina, H. Nugroho, S. Komala Sari, T. Gunawan, and D. Rahman Wijaya, "Pembuatan Konten Multimedia Untuk Penyuluhan Pertanian di Balai Penyuluhan Pertanian (BPP) Limbangan," *I-Com: Indonesian Community Journal*, vol. 3, no. 3, 2023, doi: 10.33379/icom.v3i3.2854.
- [14] Suswadi dan Sutarno, "Analisa dinamika dan kemandirian kelembagaan ekonomi petani dengan penerapan organik bersertifikat di Kabupaten Boyolali," in *PROSIDING SEMINAR NASIONAL PROGAM STUDI BIMBINGAN KONSELING 22 AGUSTUS 2017*, 2017.
- [15] Sapar, *pengantar metode penelitian kuantitatif*, V. makassar: unhas press, 2022.
- [16] Y. Hidayat, A. Ismail, and M. Ekayani, "Dampak Konversi Lahan Pertanian Terhadap Ekonomi Rumah Tangga Petani Padi (Studi Kasus Kecamatan Kertajati Kabupaten Majalengka Jawa Barat)," *Jurnal Pengkajian dan Pengembangan Teknologi Pertanian*, vol. 20, no. 2, p. 171, 2018, doi: 10.21082/jpntp.v20n2.2017.p171-182.
- [17] J. F. Hair Jr, C. M. Ringle, N. P. Danks, G. T. M. Hult, M. Sarstedt, and Ray Soumya, *Partial Least Squares Structural Equation Modeling (PLS-SEM) Using R*, 3rd ed., vol. 1. USA: Springer, 2021. doi: <https://doi.org/10.1007/978-3-030-80519-7>.
- [18] S. Setiaman, "Analisa parsial model persamaan struktural dengan software SMART-PLS Versi 3," *Tutorial*, pp. 1–95, 2020.
- [19] Z. Awang, A. Afthanorhan, and M. A. M. Asri, "Parametric and Non-Parametric Approach in Structural Equation Modeling (SEM): The Application of Bootstrapping," *Mod Appl Sci*, vol. 9, no. 9, pp. 58–67, 2015, doi: 10.5539/mas.v9n9p58.
- [20] T. Ramayah, C. Jacky, C. Francis, T. Hiram, and M. A. Memon, "Partial Least Squares Structural Equation Modeling (PLS-SEM) using SmartPLS 3.0: an Updated Guide and Practical Guide to Statistical Analysis," in *an updated guide and practical guide to statistical analysis*, vol. 2, Kuala Lumpur: Malaysia Pearson, 2017, pp. 1–27.
- [21] I. Setiajie Anugrah and J. Hestina, "Management of Agricultural Tools and Machinery as Supporting Instruments for Modern Agriculture," *Riset dan Inovasi Nasional*, vol. 40, no. 2, 2017.
- [22] B. Harahap, W. Widodo, A. Sutanto, Sapar, and Syafruddin, "The effect of the agricultural mechanization assistance model on socio-economic changes of farmer groups in Palopo city, Indonesia," *International Journal of Scientific Research and Management (IJSRM)*, vol. 12, no. 03, pp. 497–505, Mar. 2024, doi: 10.18535/IJSRM/V12I03.AH01.

- [23] C. Rickards, P. Marenya, M. Chiduwa, A. Eitzinger, M. Fisher, and S. Snapp, "Enhancing farmers' agency is a more effective extension paradigm: The case of soil health management in Africa," *Agric Syst*, vol. 225, p. 104267, Apr. 2025, doi: 10.1016/J.AGSY.2025.104267.
- [24] M. Cerjak, M. Medici, I. Faletar, J. V. Sundeep, and M. Canavari, "Adoption of mobile-based agricultural extension services: evidence from South India," *J Rural Stud*, vol. 120, p. 103851, Dec. 2025, doi: 10.1016/J.JRURSTUD.2025.103851.
- [25] C. Yang, X. Ji, C. Cheng, S. Liao, B. Obuobi, and Y. Zhang, "Digital economy empowers sustainable agriculture: Implications for farmers' adoption of ecological agricultural technologies," *Ecol Indic*, vol. 159, p. 111723, Feb. 2024, doi: 10.1016/J.ECOLIND.2024.111723.
- [26] K. Kusnandar, O. van Kooten, and F. M. Brazier, "Supporting self-organisation in farmer organisations in developing countries: A case with a group of farmer groups in Indonesia," *Journal of Co-operative Organization and Management*, vol. 11, no. 2, p. 100214, Dec. 2023, doi: 10.1016/J.JCOM.2023.100214.
- [27] K. Winarno, J. Sustiyo, A. A. Aziz, and R. Permani, "Unlocking agricultural mechanisation potential in Indonesia: Barriers, drivers, and pathways for sustainable agri-food systems," *Agric Syst*, vol. 226, p. 104305, May 2025, doi: 10.1016/J.AGSY.2025.104305.
- [28] M. Salam *et al.*, "The effectiveness of agricultural extension in rice farming in Bantaeng Regency, Indonesia: Employing structural equation modeling in search for the effective ways in educating farmers," *J Agric Food Res*, vol. 18, p. 101487, Dec. 2024, doi: 10.1016/J.JAFR.2024.101487.
- [29] P. M. Danjumah, M. T. Asiamah, E. K. Tham-Agyekum, S. A. Ibrahim, and L. K. Mensah, "Dynamics of agricultural extension delivery services to rice farmers in Ghana," *Heliyon*, vol. 10, no. 5, p. e26753, Mar. 2024, doi: 10.1016/J.HELIYON.2024.E26753.
- [30] L. Adam, J. Jin, and A. Khan, "Does the Indonesian farmer empowerment policy enhance the professional farmer? Empirical evidence based on the difference-in-difference approach," *Technol Soc*, vol. 68, p. 101924, Feb. 2022, doi: 10.1016/J.TECHSOC.2022.101924.
- [31] L. Mozumdar, S. Lindgren, and N. Nishat, "Modern agrotechnology, women's empowerment and poverty reduction nexus: Mediation of farm performance; empirical evidence on BAU-STR dryer," *World Dev Perspect*, vol. 37, p. 100673, Mar. 2025, doi: 10.1016/J.WDP.2025.100673.
- [32] J. Blesh *et al.*, "Against the odds: Network and institutional pathways enabling agricultural diversification," *One Earth*, vol. 6, no. 5, pp. 479–491, May 2023, doi: 10.1016/J.ONEEAR.2023.03.004.
- [33] M. M. Rana, L. Kiminami, and S. Furuzawa, "An analysis of factors affecting farmers' capacity building for sustainable rural and agricultural development in Bangladesh," *Regional Science Policy & Practice*, vol. 17, no. 8, p. 100202, Aug. 2025, doi: 10.1016/J.RSPP.2025.100202.
- [34] Z. Fu, C. Zhang, Z. Huang, L. Jia, G. Sun, and W. Wang, "Advancing sustainable and innovative agriculture: An empirical study of farmers' livelihood risks and the green transformation of food production," *Journal of Innovation & Knowledge*, vol. 10, no. 4, p. 100732, Jul. 2025, doi: 10.1016/J.JIK.2025.100732.